

VIBER MP™ -System



Machine monitoring and Protection - System.

User manual
Version 1.3

User manual



Machine monitoring and Protection - System.



Index		page
1	Important information	4
2	Introduction	5
3	General description	6
4	Recommended measuring directions and transducer locations according to ISO 10816-3	8
5	Excerpt from ISO standard	9
6	Alarm settings	10-12
7	How to connect VIBER MP™ -System	15-18
7.1	Power/Relay	19-20
8	Description of transducer settings	21
8.1	Accelerometer setup	21-24
8.2	Velocity sensor HG-91 Setup	25
8.3	Proximity prob KIN-M18 Setup	26-27
8.4	Temperature measurement with TA-102 Setup	28
8.5	Temperature measurement with Pt-100 Setup	29
8.6	Connections to the modules and Flash/Tone	30-32
9.0	Application example	33
9.1	Application example for 2 measurement points	33
9.2	Application example for 5 measurement points	34
9.3	Application example for 8 measurement points	35
10	Technical data	36



1. Important information

VMI takes no responsibility for any accidents on people and machines.

VMI and our authorized dealers will take no responsibility for damages on machines and plants as the result of the use of **VIBER MP™ -System** measurements.



2. Introduction

VIBER MP™ -S is a flexible, reliable and easy to use analogy machine monitoring and protection system. The **VIBER MP-System** can be supplied with a **Power/Relay-** module that allows for the shutdown of the machine, in case you do not have access to a PLC- system. **VIBER MP™ -S** will give alarm or stop the machine if failure occurs and the settings for **warning** or **danger** are exceeded. **VIBER MP™-S** continuously measures machine vibration, sensor and cable status, information can be transferred by an external **PLC*** to the control room. **VIBER MP™ -S** has a secure local alarm transfer to the control room, (does not use internet).

VIBER MP™ -S is available with the following configurations/channels;

- 1) Vibrations velocity: mm/s, Measured with Accelerometer
- 2) Vibrations velocity: mm/s, Measured with velocity sensor
- 3) Bearing Condition acceleration, gBC-value, Measured with Accelerometer
- 4) Bearing Condition: mm/s, Measured with Accelerometer
- 5) Displacement: μm , Measured with proximity probe
- 6) Temperature: $^{\circ}\text{C}$, Measured with combined Temperature and Vibration sensor
- 7) Temperature: $^{\circ}\text{C}$, Measured with pt100 sensor

The Relays on the "Power/Relay module" are controlled from all the channels

- Two independent *change-over-relays* for **warning** and **danger** alarm. (Rly1_W and Rly1_D).
- One *change-over-relay* for **transducer** or **cable** failure. (Rly1_E).
- Two independent **time delays adjustments** of relay function. (P1_D, P1_W).
- The time delay of relay activation is adjustable between (0 - 30 sec) or (3 - 30sec).

* PLC = programmable logic controller



3. General description

The transducer signal is compensated in the input amplifier to correct signal level and selected frequency range. The AC-monitor BNC-output, on the front panel, follows the transducer signal, enabling the connection of another vibration instrument for extended analysis. Only the vibration signal is available from the AC-monitor BNC-output. The AC-monitor- signal is also accessible between terminals AC out and GND.

In addition to the accelerometer, there is also the possibility of connecting a velocity sensor and a proximity probe as well as sensor for temperature.

What type of configuration the modules (channels) should have on delivery is determined by the customer when ordering.

When accelerometer or velocity transducer are used, the analysis, alarm and current signals (mA) are always measured in velocity (mm/s). This signal can be, for velocity, amplified in 3 selectable ranges 0 - 10, 0 - 20 and 0 - 100 mm/s. Select the measuring range closest to the maximum permissible vibration.

The instrument measures the RMS value of the signal within the selected frequency range.

The signal level is converted to a corresponding current output between 4- 20 mA. This signal is available on terminals for connection to other instruments or data logger. The current output is disabled in case of transducer or cable failure.

The output current from **VIBER MP™ -S** to **PLC** is 4 - 20 mA. Max load in **PLC**, should not be higher than 600 ohm (12V, 20 mA). This refers to 100% of selected measuring range. If the customer connects the system to a PLC equipment with software then no Power/Relay module is required.



The enclosure, consists of a flexible modular system, DIN rail connections for the electronics ME-MAX system. As an accessory, the modular system can be mounted in an IP-65 cabinet.

4. Recommended measuring directions and transducer locations according to ISO 10816-3.

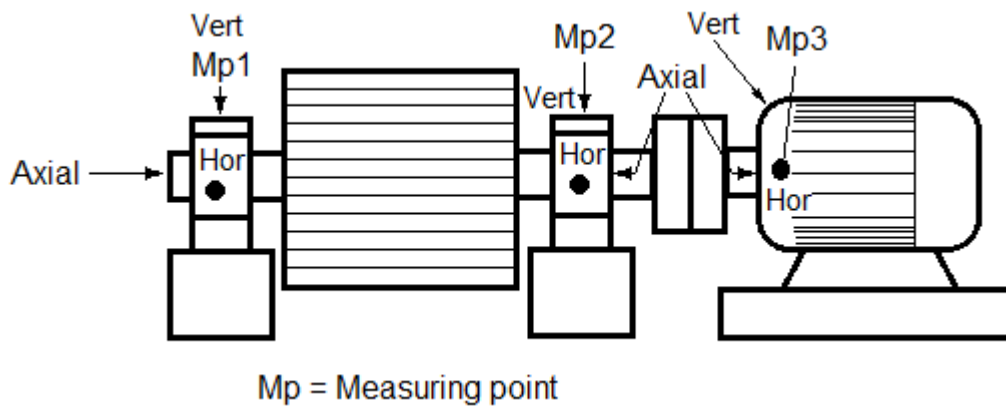

fig.1

Measure on or as near to the bearings as possible.

Measure vertically and horizontally in direction that points to the shaft centre.

Measure axially in the same height as the shaft centre.

Do not measure on thin sheet metal plates.

Before permanently mounting the transducer measure on the position as suggested in fig 1. For monitoring purpose use one of the measuring points with the highest vibration.



5. Excerpt from ISO standard

ISO Standard 10816-3 classifies machines differently depending on whether they are flexible or rigid (fixed) mounted. This reflects the location of the machine's "rigid resonances" related to the machine's operating speed.

Examples of vibration levels ISO standards

Vibration mm/s	Class 1	Class 2	Class 3	Class 4
0.28	A	A	A	A
0.45				
0.71				
1.12	B	B	B	A
1.8				
2.8	C	C	B	B
4.5				
7.1	D	D	C	C
11.2				
18				
28	D	D	D	D
45				

Class 1: Small machines, Electric motors below 15 kW

Class 2: Medium-sized machines, Electric motors 15 - 75 kW

Class 3: Large machines, rigid foundation

Class 4: Large machines, weak foundations

A = Good

B = Satisfactory

C = Unsatisfactory

D = Unacceptable

Rigid mounting usually means that the machine is directly mounted on a concrete foundation.

Flexible mounting usually means that the machine is mounted on flexible feet or a weak steel structure.



6. Alarm settings when using Power/Relay-modul

When the alarm levels are to be set, press the toggling button as toggling between the vibration level and the alarm level. The display shows the alarm level in mm/s for the vibration modules. Other measurement modules show other units of measurement. Alarm levels are adjusted with alarm level potentiometers. Both the **warning** and the **danger** alarm level can be adjusted independently of each other.

When the preset alarm levels are reached or exceeded a LED lamp is lit. If you do not want the alarm to be resolved immediately, you can adjust a delay time within 0 - 30 sec. If the alarm levels last longer then the selected delay time (0 - 30 sec) then the relay is changing. The **VIBER MP™ -S** has Manual or Automatic resetting of the alarm status. **Alarm reset:** When **J1_WA** and **J1_DA** are not strapped on the measurement module, **Autoreset** is enabled. When **J1_WA** and **J1_DA** are strapped on the measurement module, **manual reset** is enabled. What type of reset the customer want to have is decided upon the ordering. Adjustment of delay times is performed with trim potentiometers (**P1W, P1D**) on the front of the "Power / Relay" module.

If **VIBER MP™ -S** is connected to a **Power switch** (see pages 17-18) that turns off the machine, then it is recommended to choose the manual reset of dangerous alarm. If auto reset is selected in this mode, **the machine will restart again** when the vibration has decreased below the set alarm level.

Auto-reset is recommended when short pulse vibrations occur which are shorter than the set delay time. In that case, the machine will not shut down. If the vibrations are continuously ongoing, then the machine shuts off when the delay time has expired. **When auto reset is selected, remember that the machine will start again when the vibration falls below the set alarm level.** If the vibrations are continuously ongoing, turn off the machine manually.

The stop function is only suitable for use with machines that do not cause impulse vibration.



If the alarm RESET button is set in manual mode, the alarm indicator and the relay will stay in alarm mode until the alarm RESET button is pushed.

Note. When the system has started up for the first time or after power failure, you must reset all manual alarms by pressing the Alarm reset button.

All channels control the same relays on the mother board. Rly1_W, Rly1_D and Rly1_E. As an accessory, a flashing and sounding device (FlashTone), can be mounted together with the **VIBER MP™ -S**.

VIBER MP™ -S must after start up, stabilize before measurements are reliable, this takes about 20 to 30 sec depending on the frequency range you have selected. This means that the relay controlled units can not be activated before the **VIBER MP™ -S** is stable. To measure correctly wait about: 10 min.

When servicing and repair a machine, always disconnect the main power supply.

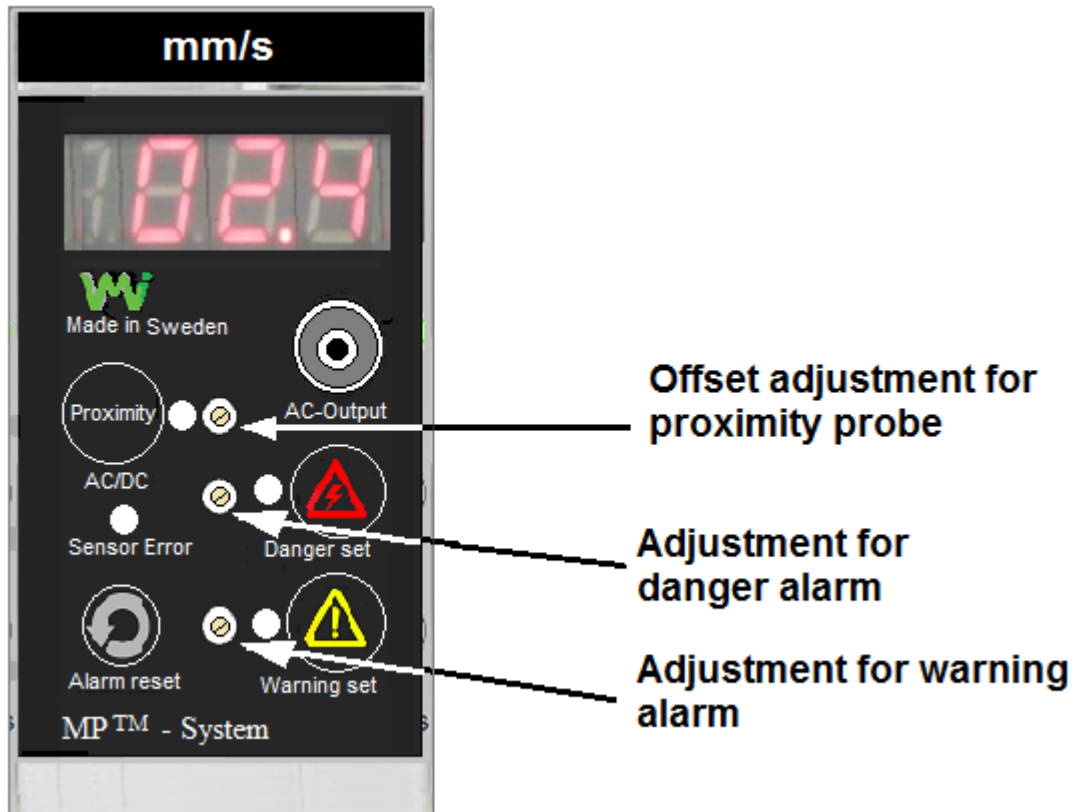

Press the **red** triangle button and turn the trimmer for "Danger alarm" until the desired alarm level is set.

Press the **yellow** triangle button and turn the trimmer for "Warning alarm" until the desired alarm level is set.

Press the "Alarm reset" to reset the alarm status if manual alarm reset is selected.

Press the Proximity button to choose between AC or DC. (Only for proximity probe).

Use a **Power/Relay** module in case you do not have access to a PLC system.

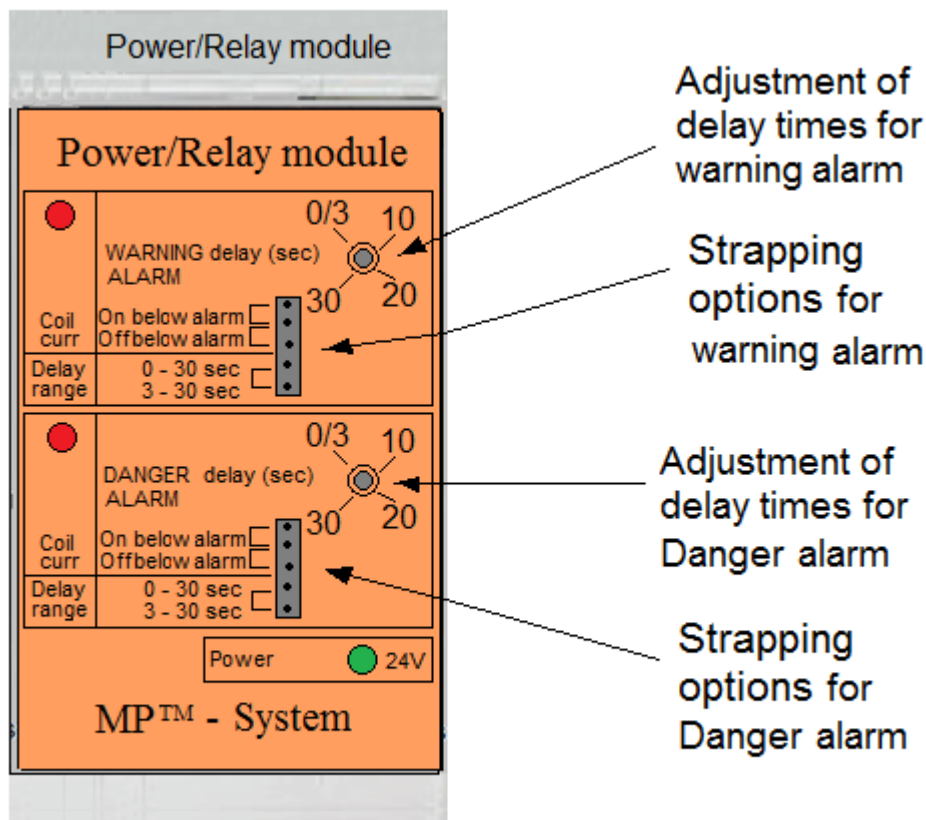

Adjustment of delay times is performed with trim potentiometers (P1W, P1D) on the front of the "Power / Relay" module. **Without the jumper mounted**, for the selection of 0-30 or 3-30 sec, it is not possible to set the delay time below 3 sec.

Relay coil

With the front jumper, in the upper part, it is possible to select if the relay coil shall be energized **above** or **below** the alarm limit. With the jumper in position "**On below alarm**" the relay coil is energized if the vibration is below the alarm limit. With the jumper in position "**Off below alarm**" the coil is energized if the vibration is above the alarm limit.

The **VIBER MP™ -S** is factory set with the front jumper in position "**Off below alarm**" (the relay coil is energized if the vibration is above the alarm limit).



If you control the machine with a PLC- equipment then no **Power/Relay-module** is required. It is then replaced with an external power supply.

7. How to connect VIBER MP™ -S

On the sensor cables are mounted 4-pin header connectors.

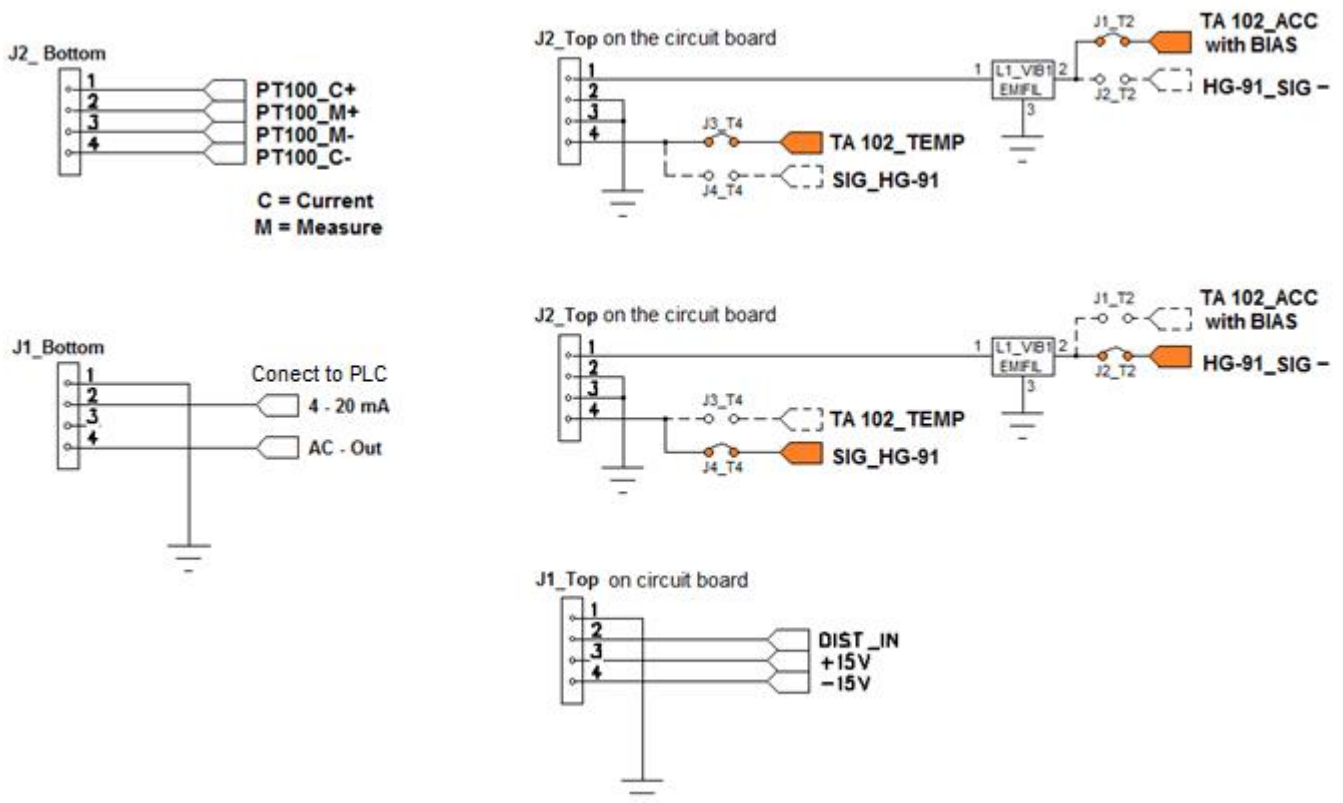

Connection of different types of sensors

The channels that are not used must be terminated on the inputs with a resistance of approx. 3,0 - 3,3 KΩ, especially when the lower limit frequency is selected to 2Hz. When selecting 2 Hz as the lowest frequency, the self-noise increases, which means that the instrument does not go down to zero.

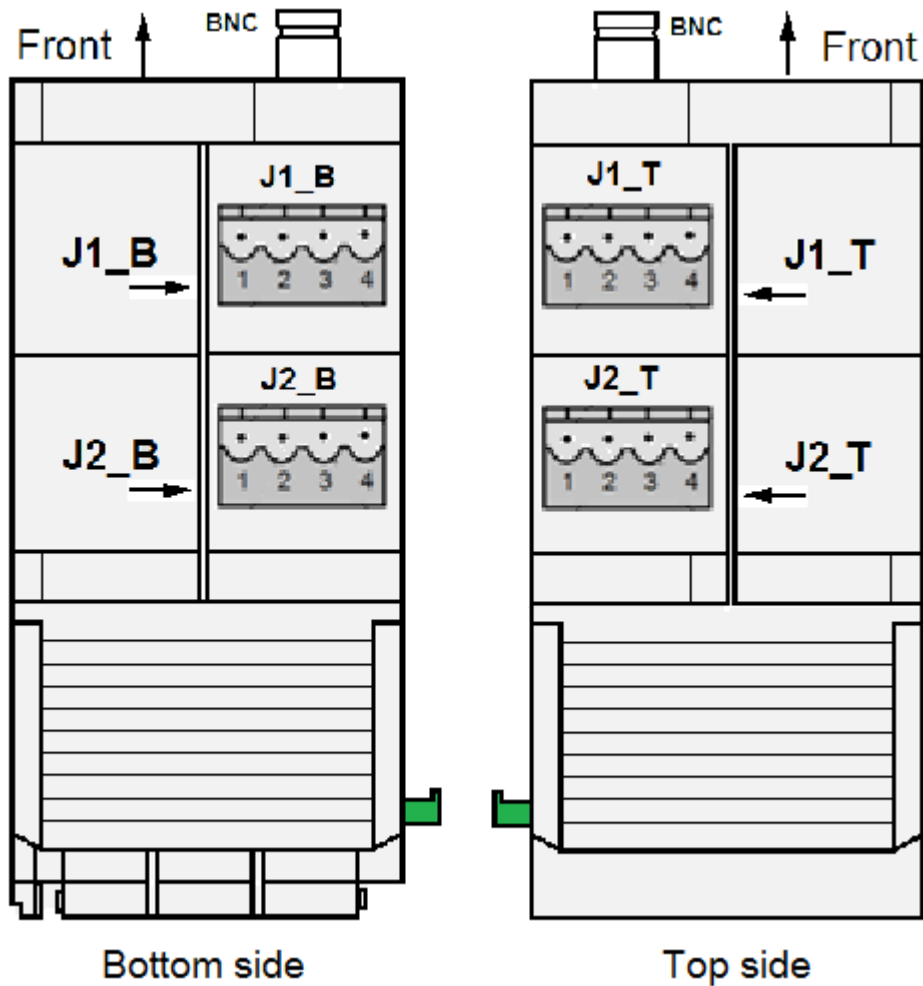

The connectors seen on the module's top side and bottom side.

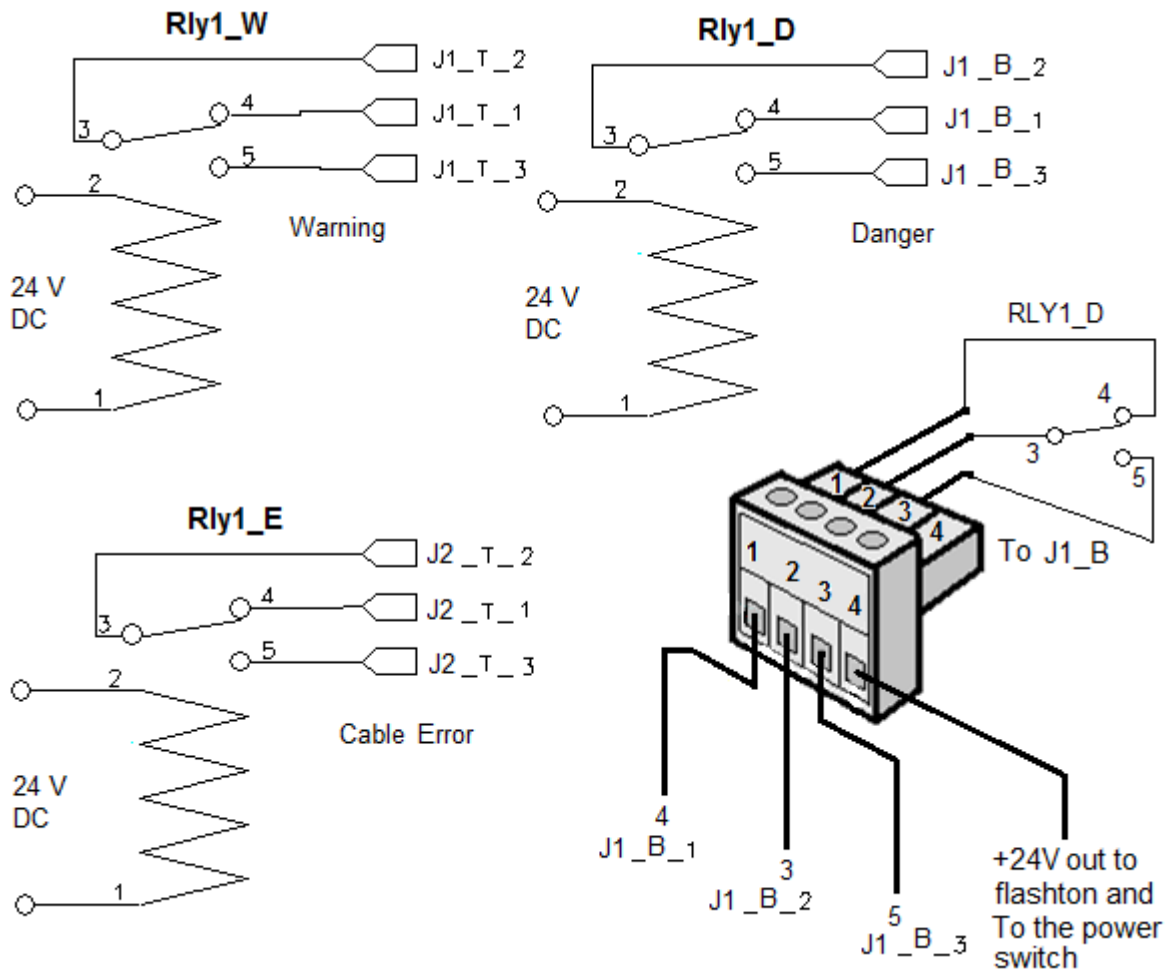

Connection of relays

Very important:

Maximum transmitted continuously power for internal terminals in **VIBER**

MP™ -S, for relay output 1, relay output 2 and relay output 3, is **50 W**.

Maximum voltage is **50 V DC** and max current is **1,0 A**. If higher transmitted and breaking power is needed, a "**High power switch**" must be connected between **VIBER MP™ -S** and the power consumption. +24V to the "flash/ton" unit can also be used to control the power switch. This installation must be performed by a qualified electrician with a certificate.

Note. When the system has started up for the first time or after power failure, you must reset all manual alarms.



Example of a power switch

This is an accessory that is not provided by VMI

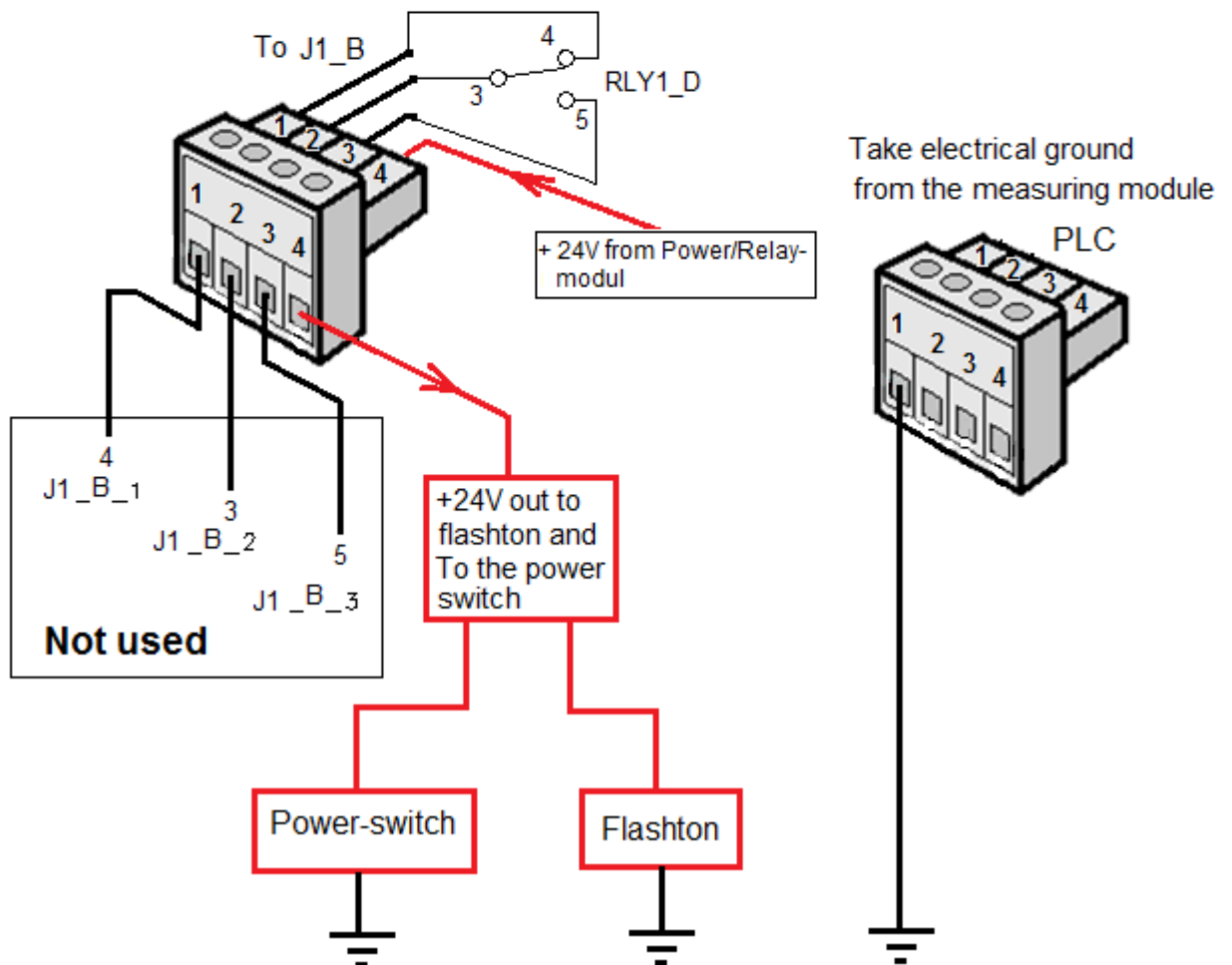

7.1 Connections to the Power/Relay module.

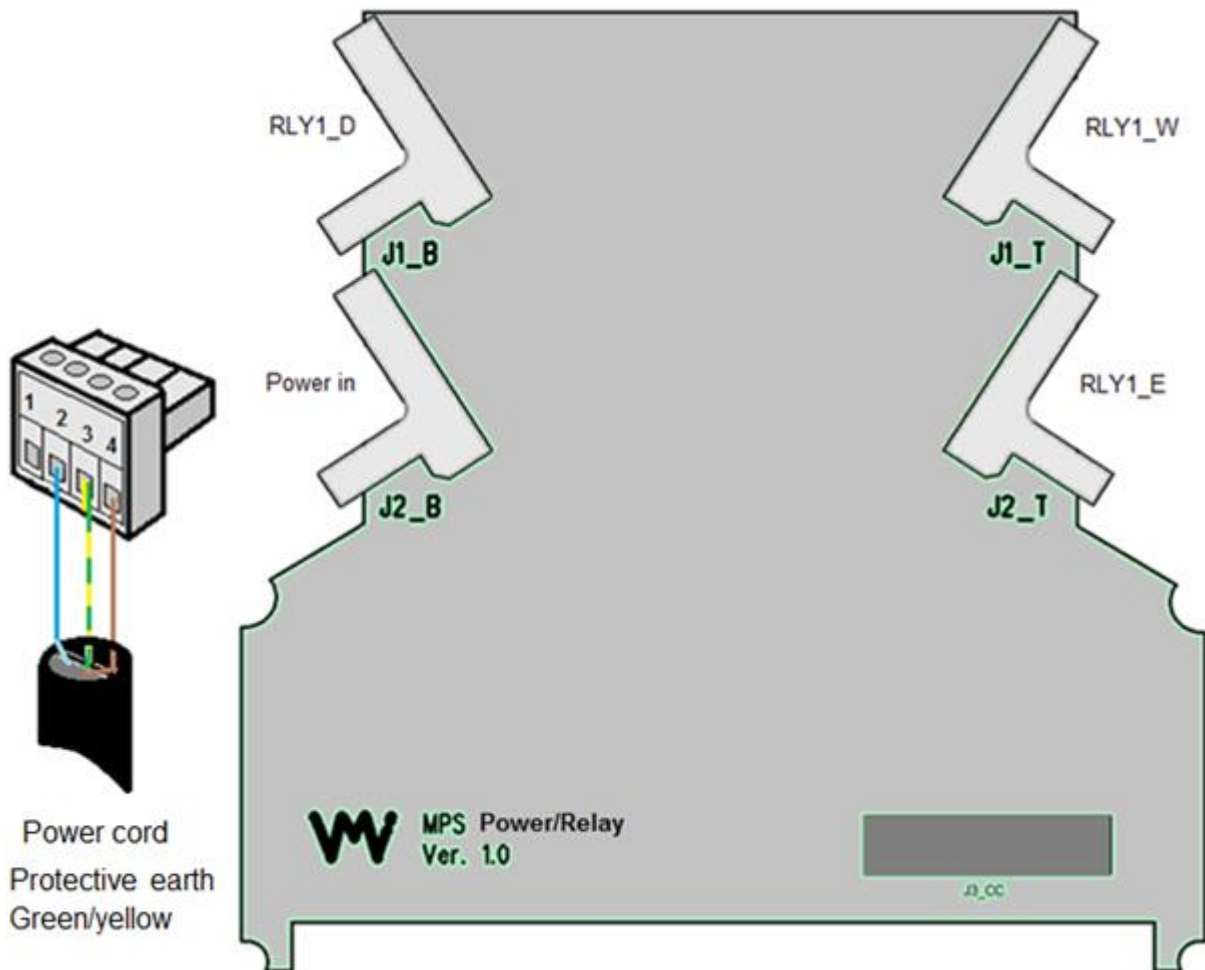

At 24V, + to pin 4 and - to pin 2.

Contacts labeling for the **Power/Relay module**:

Power in: **J2_B**. (Be sure to connect to the correct contact).

Relay for Danger Alarm: RLY1_D, **J1_B**

Relay for Warning Alarm: RLY1_W, **J1_T**

Relay for Sensor Error: RLY1_E, **J2_T**

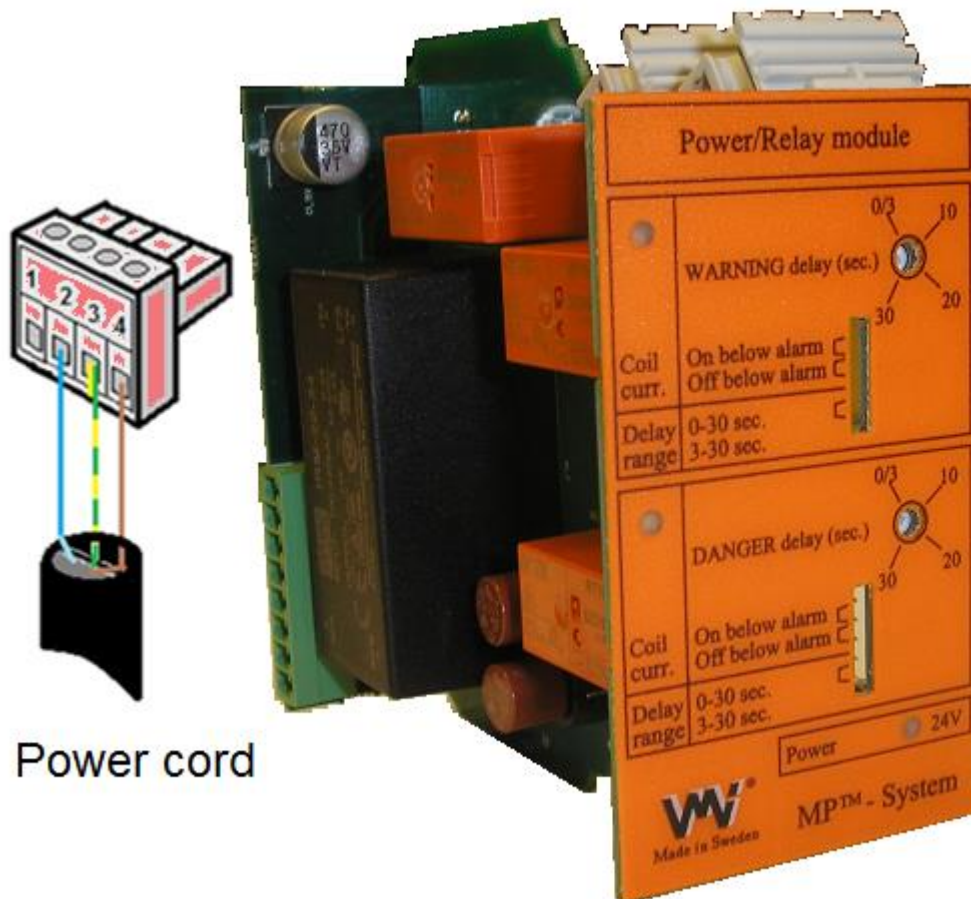

The power/relay module can drive six to eight measurement modules depending on configuration and type.

NOTE. The power cable to the Power / Relay module has also a 4-pin header connector mounted on the cable. **Be sure to connect to the correct contact.**

8. Description of transducer settings

8.1 Accelerometer Setup

VIBER MP™ -S has an integrating amplifier for accelerometer that converts acceleration to velocity. It has a 4 mA constant current generator at maximum 20V DC, for power supply of the sensor. The sensitivity for the accelerometer is preset to 100 mV/g. If higher accuracy is desired, it's necessary to adjust the sensitivity level as for the used accelerometer. Accuracy when measuring low vibration levels will decrease, if higher measuring ranges are chosen. **VIBER MP™ -S** has the following measurement ranges for velocity: 0 - 10 mm/s, 0 - 20 mm/s and 0 - 100 mm/s. When measuring vibration expressed as acceleration in g-values: 0 - 1g, 0 - 2g and 0 - 10g.

Band pass filter

The lower limit frequency is selectable between two frequencies 2 or 10 Hz. The upper frequency limit is selectable between two frequencies 1KHz or 3,8 KHz. without filter, the red line in the diagram, gives: 2 Hz - >10KHz
For Bearing Condition (B.C) 500 Hz - 16KHz.

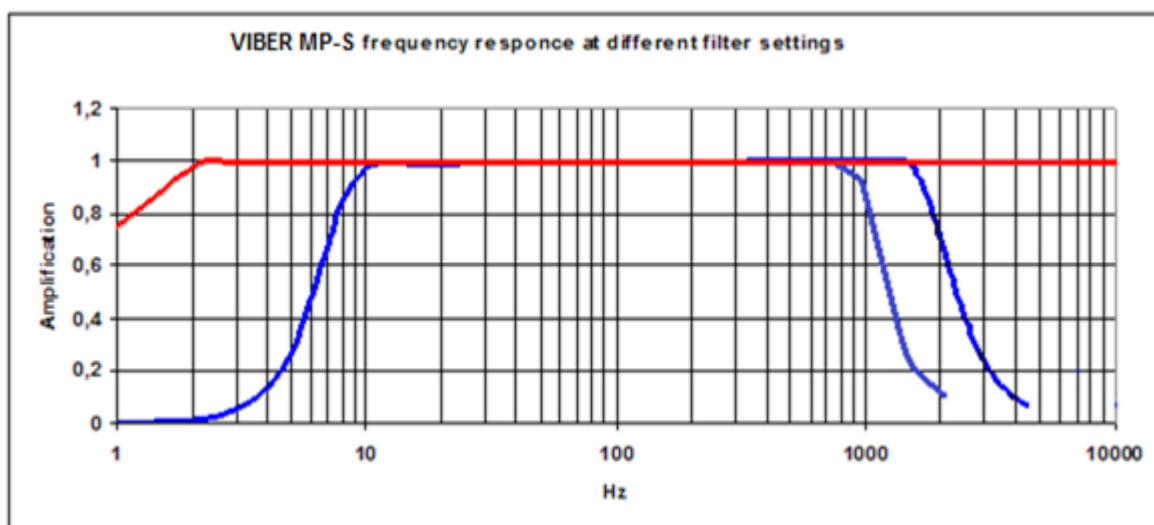

There are six different setting options for the frequency range.



When measuring Bearing Condition B.C: Select at low rotational speeds 0 - 1 gBC, at medium speeds 0 - 2 gBC, and at high speeds 0 - 10 gBC.

Based on the machines measured “gBC-value”, follow the line corresponding to the measured “gBC-value” on the left-hand axis, towards the line in the centre of the chart that corresponds to the machines speed. Depending on which of the four lines in the centre of the chart, which corresponds to the other two values, (gBC and RPM), you can get the following information about the bearing: GOOD, ACCEPTABLE, USEFUL and WORN.

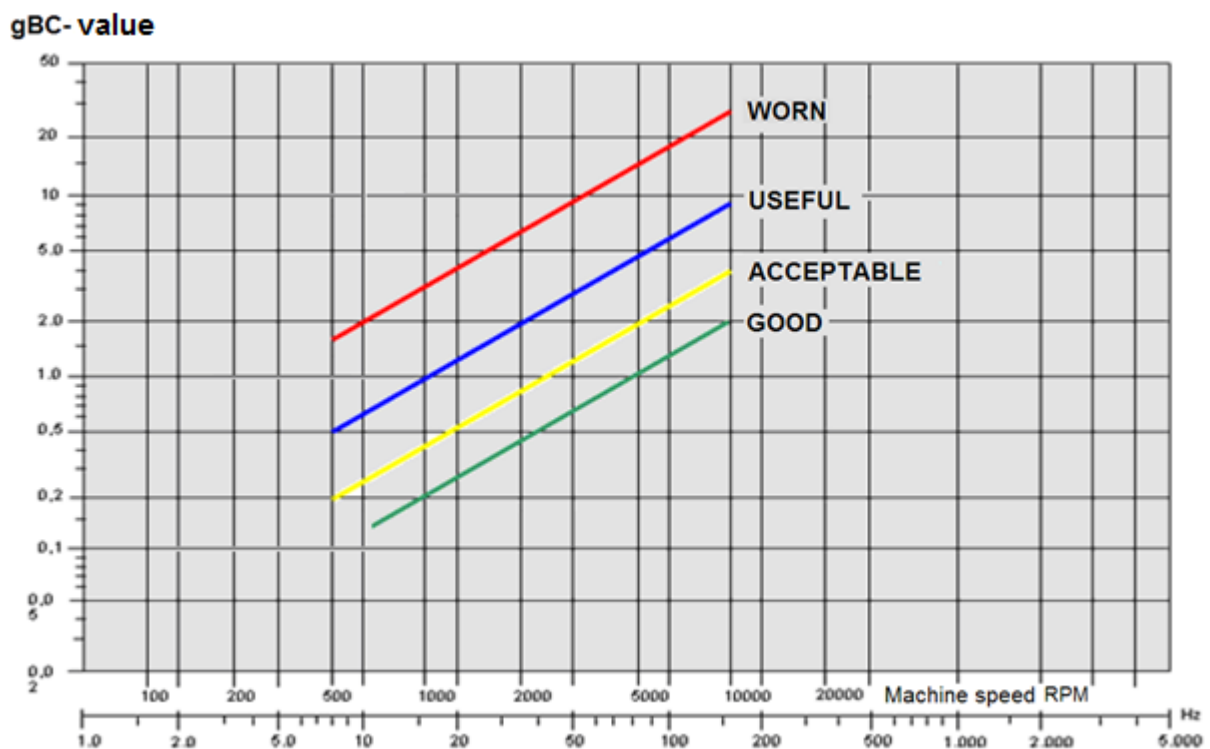

The diagram above is a help to translate bearing condition values. About, for example the measured gBC value is 2g. It shows that if a machine has a speed of approximately: 10000 RPM, the bearing may still be good, while a machine with a speed of about 550 RPM with the same gBC value can be considered as consumed.



Strap on the circuit board for Accelerometer

J2_Top on the circuit board

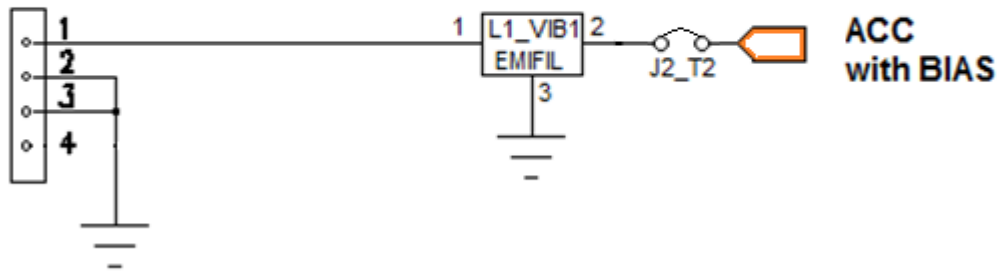

connecting cable
for accelerometer

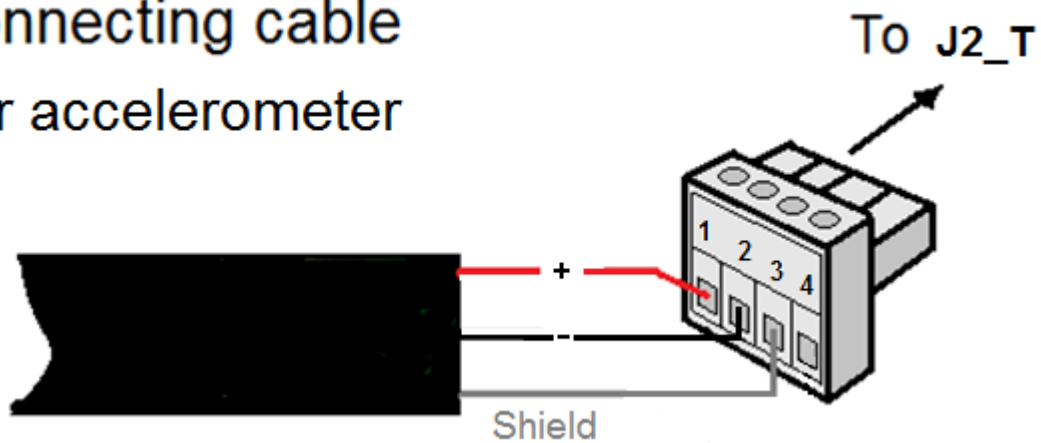

On the sensor's connecting cable, one **(4-pin) header connector** is mounted.

You can measure both **vibration velocity** and **Bearing Condition B.C.**, with one and the same accelerometer, if you can use the same measuring point.

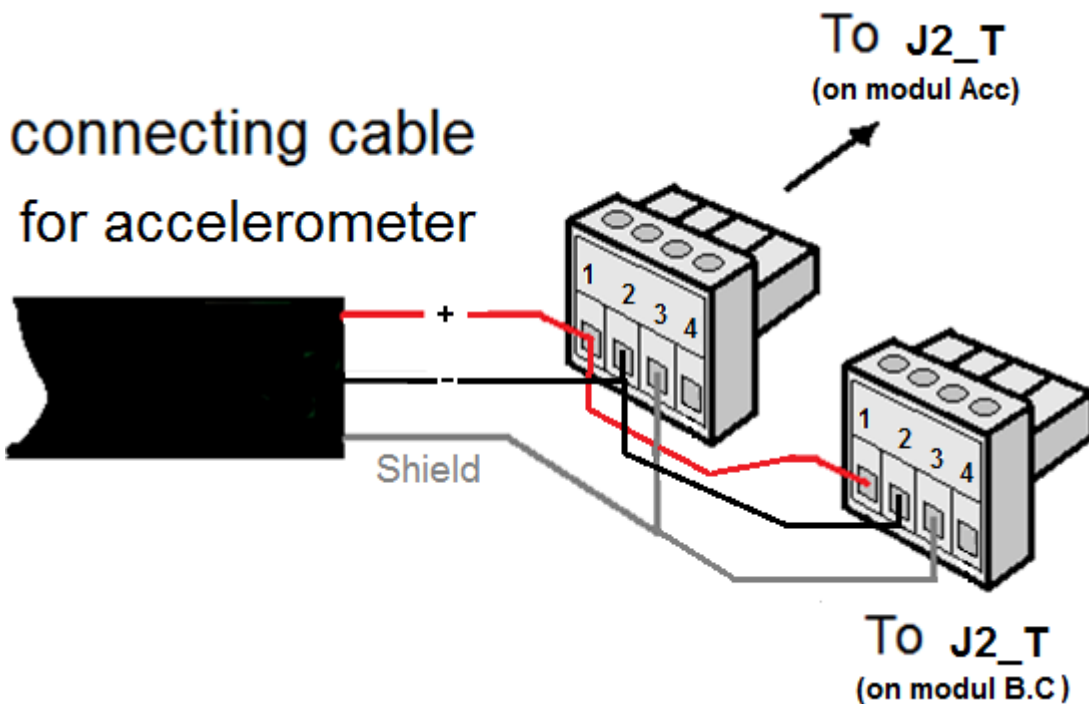

When only one accelerometer is used for simultaneous measurement of both acceleration and bearing condition, use two measurement modules, one for acceleration and one for bearing condition. **Note** that in this case must one of measuring modules power supply to the accelerometer be broken. This must be determined when ordering the system. Can not be changed afterwards.

8.2 Velocity sensor HG-91 Setup

VIBER MP™ -S has an input amplifier for velocity HG-91, it is an amplifier with a frequency compensated output. The frequency range for velocity sensors are approx. 25 - 1600 Hz (-3dB), impedance ca: 300 ohm. With frequency compensation: 10 Hz - 4 KHz. The sensitivity is approx.: 5 mV / (mm/s).

Strap on the circuit board for HG-91 Velocity sensor

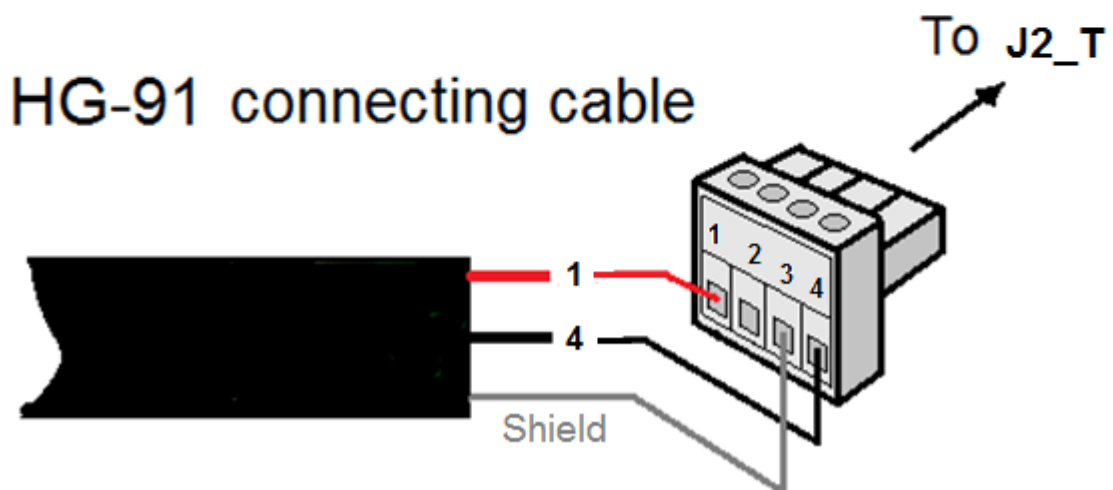
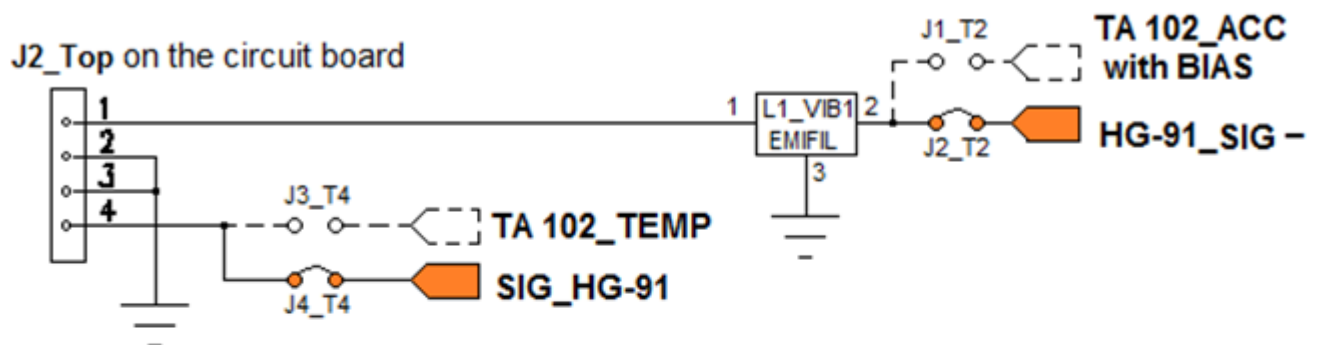

On the sensor's connecting cable, one **(4-pin) header connector** is mounted.

8.3 Proximity prob KIN-M18 Setup

VIBER MP™ -S has an input amplifier for measurement of **Displacement** with an KIN-M18 proximity probe, it is an amplifier with a flat frequency curve. There are two possibilities to connect to the input, either via a coupling capacitor, AC in, or direct DC in. When using DC in, there is an adjustment for zero-offset. The sensitivity is approx: 4V / mm.

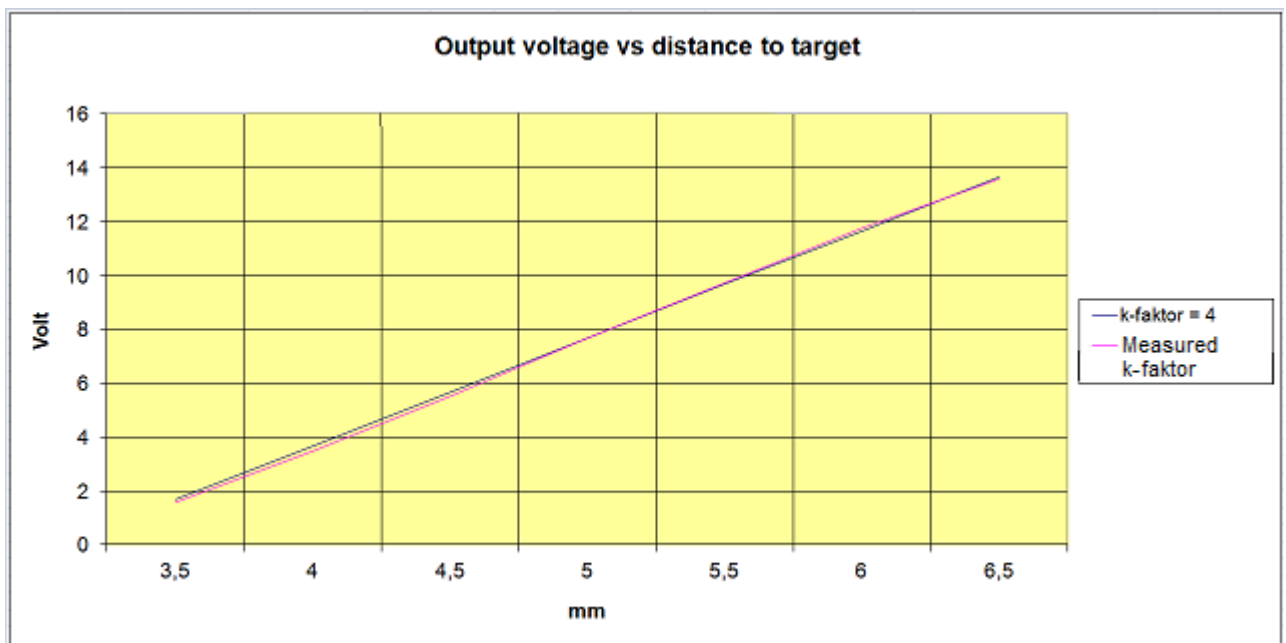

The diagram shows the output voltage as a function of the distance to the target.

VIBER MP™ -S has the following measurement ranges for displacement:
0 - 1000 μm (peak).

This measurement method is suitable for measurement on, for example, wobbling shafts. If the measuring object is made of a other material than carbon steel, for example copper or aluminum, then a new calibration of the sensor must be done.

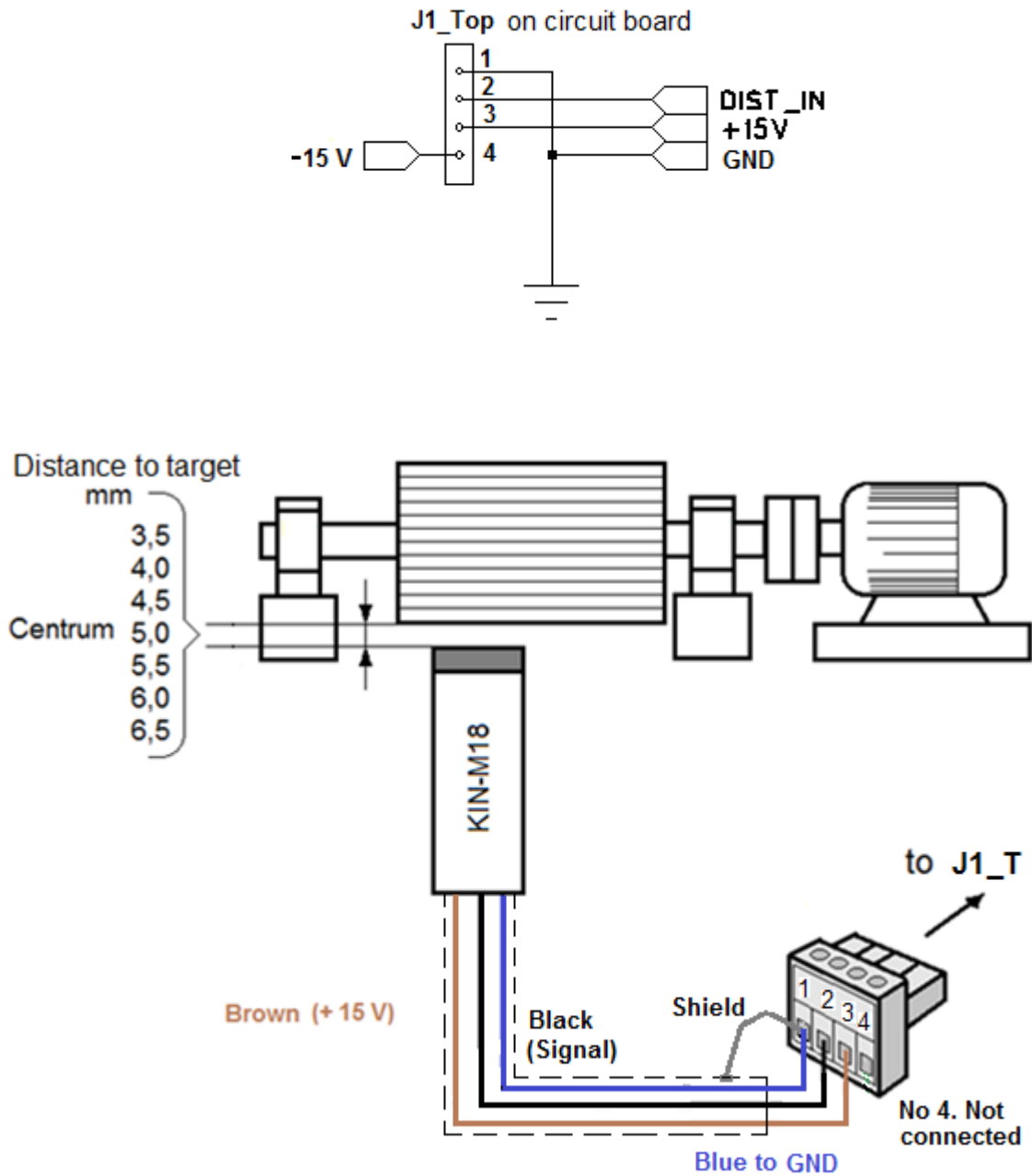

On the sensor's connecting cable, one **(4-pin) header connector** is mounted. A parallel resistance of approximately: 1.8 Kohm and a capacitor of approximately: 180 nF are mounted in parallel to the input.

8.4 Temperature and ACC. measurement setup with TA-102 or equivalent.

VIBER MP™ -S has an input amplifier for temperature with TA-102, it is an amplifier with a flat frequency curve. The sensitivity is approx: 10mV/ °C.

The **VIBER MP™ -S** has the following measurement ranges for temperature with **TA-102**: 3 - 120 °C. Response time for TA-102 is approximately: 30 min.

Strap on the circuit board for TA 102. ACC and Temp.

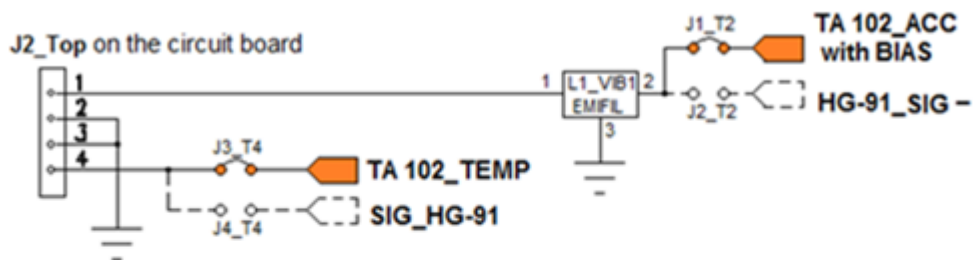

TA102 Sensor
seen from behind

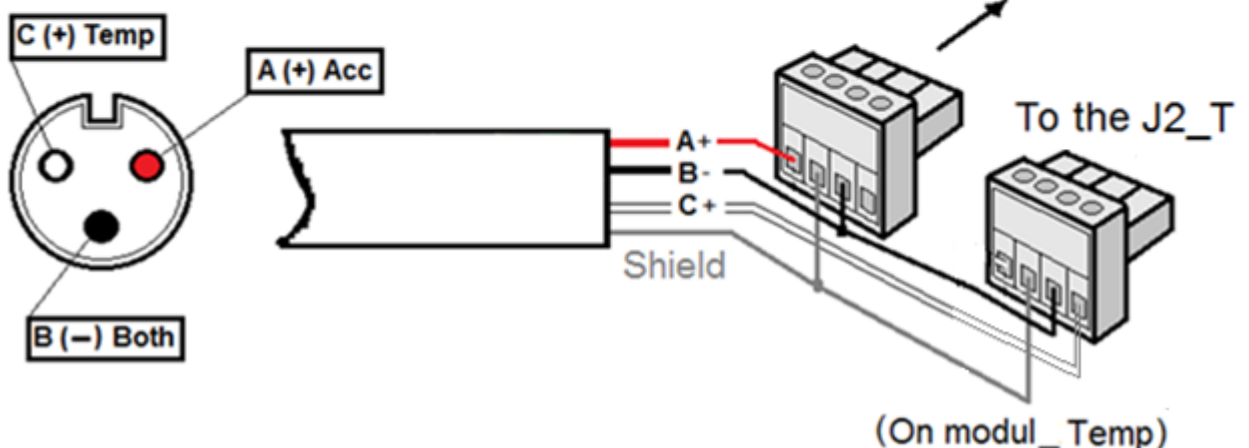

On the sensor's connecting cable, two (**4-pin**) **header connector** is mounted. TA102 requires two measurement modules, one for accelerometer and one for temperature.

8.5 Temperature measurement with Pt-100 Setup

VIBER MP™ -S has an input amplifier for temperature with Pt-100, it is an amplifier with a flat frequency curve.

The **VIBER MP™ -S** has the following measurement ranges for temperature with **Pt-100**: 0 - 120 °C. (100 Ω @ 0 °C). The response time of the Pt-100 depends on the design of the enclosure.

On the sensor's connecting cable, one (4-pin) header connector is mounted.

Connecting cable
for pt-100

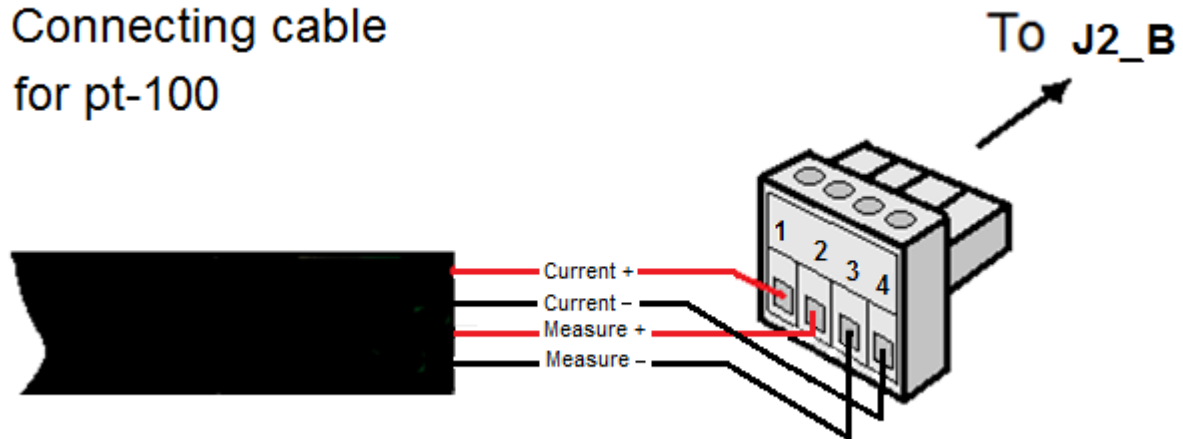

Four wire measurement

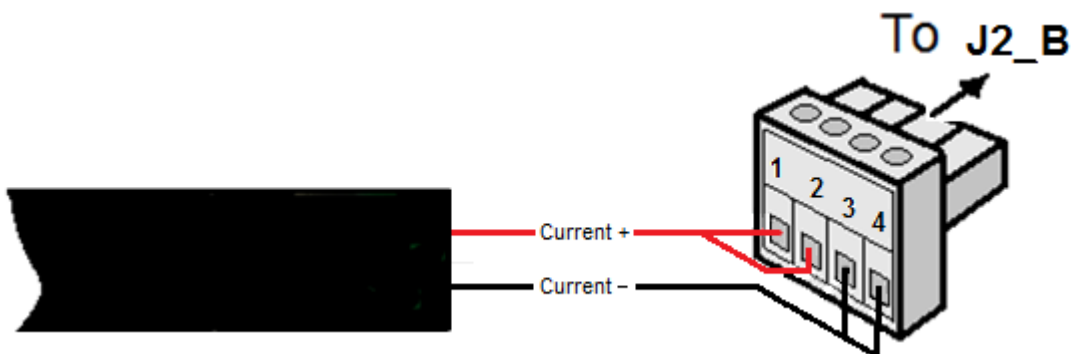

Two wire measurement



8.6 Connections to the measurement modules. Connection of Flash/Tone.

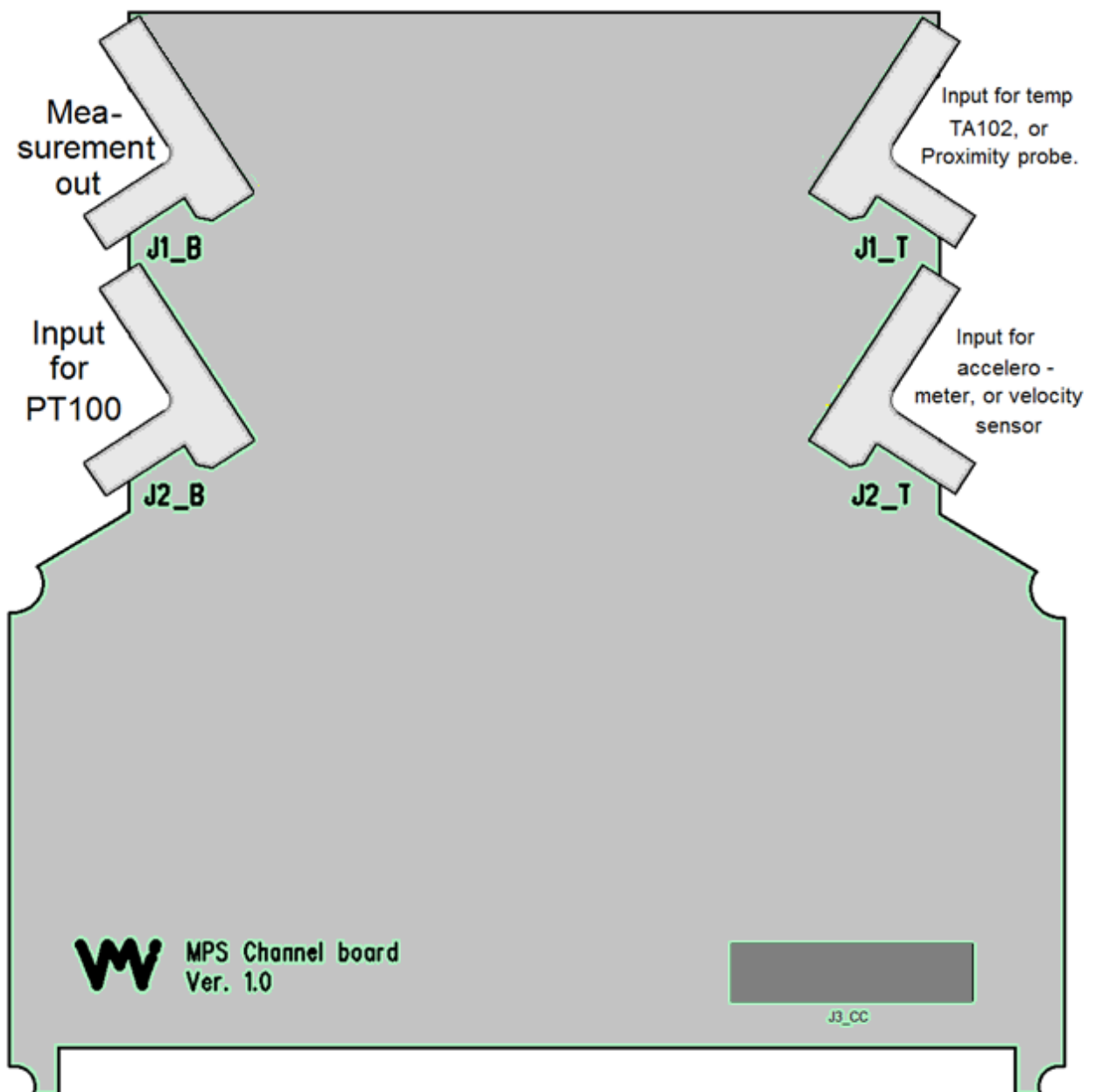

Contacts labeling for the **Measurement module** .

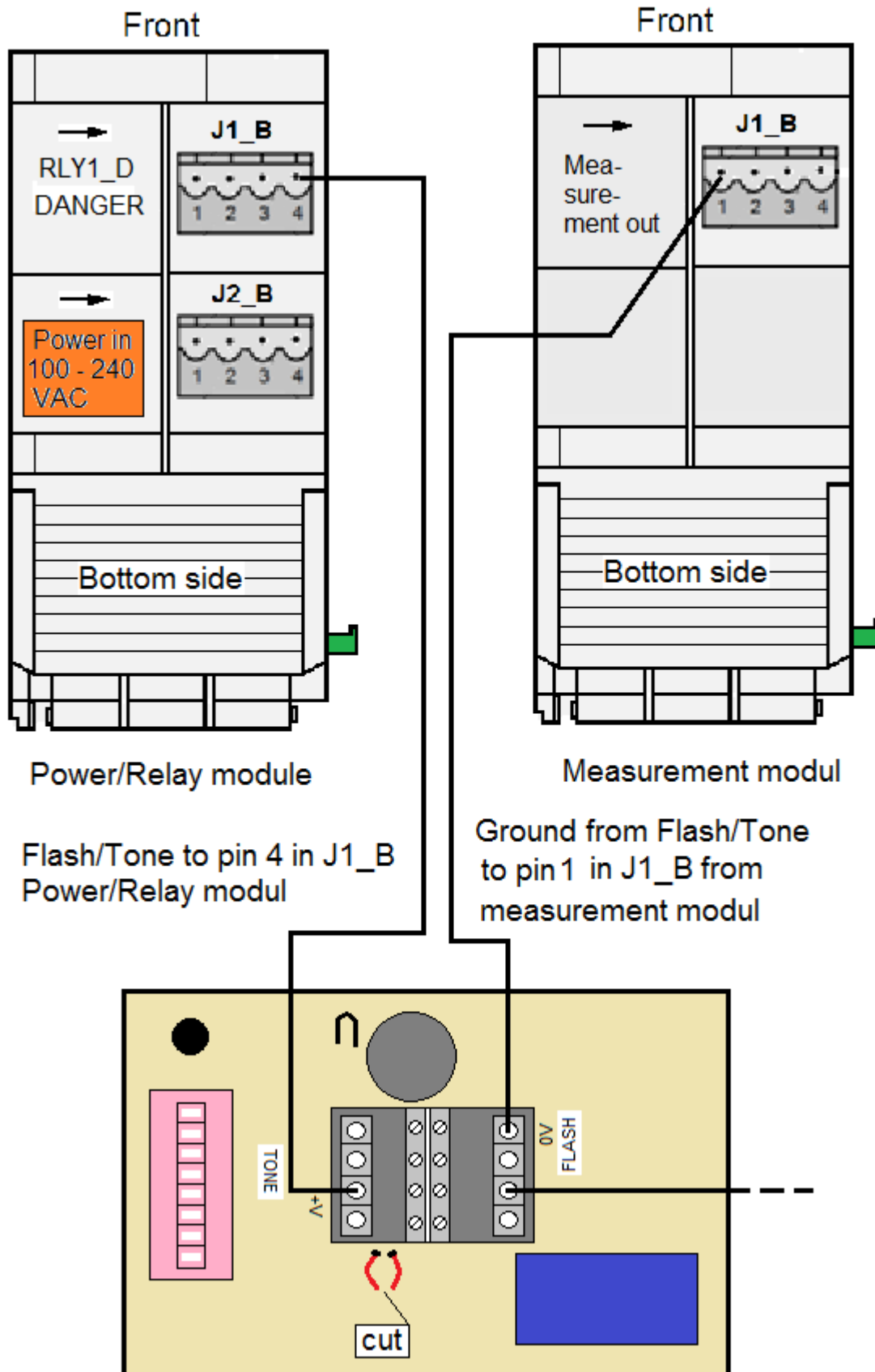

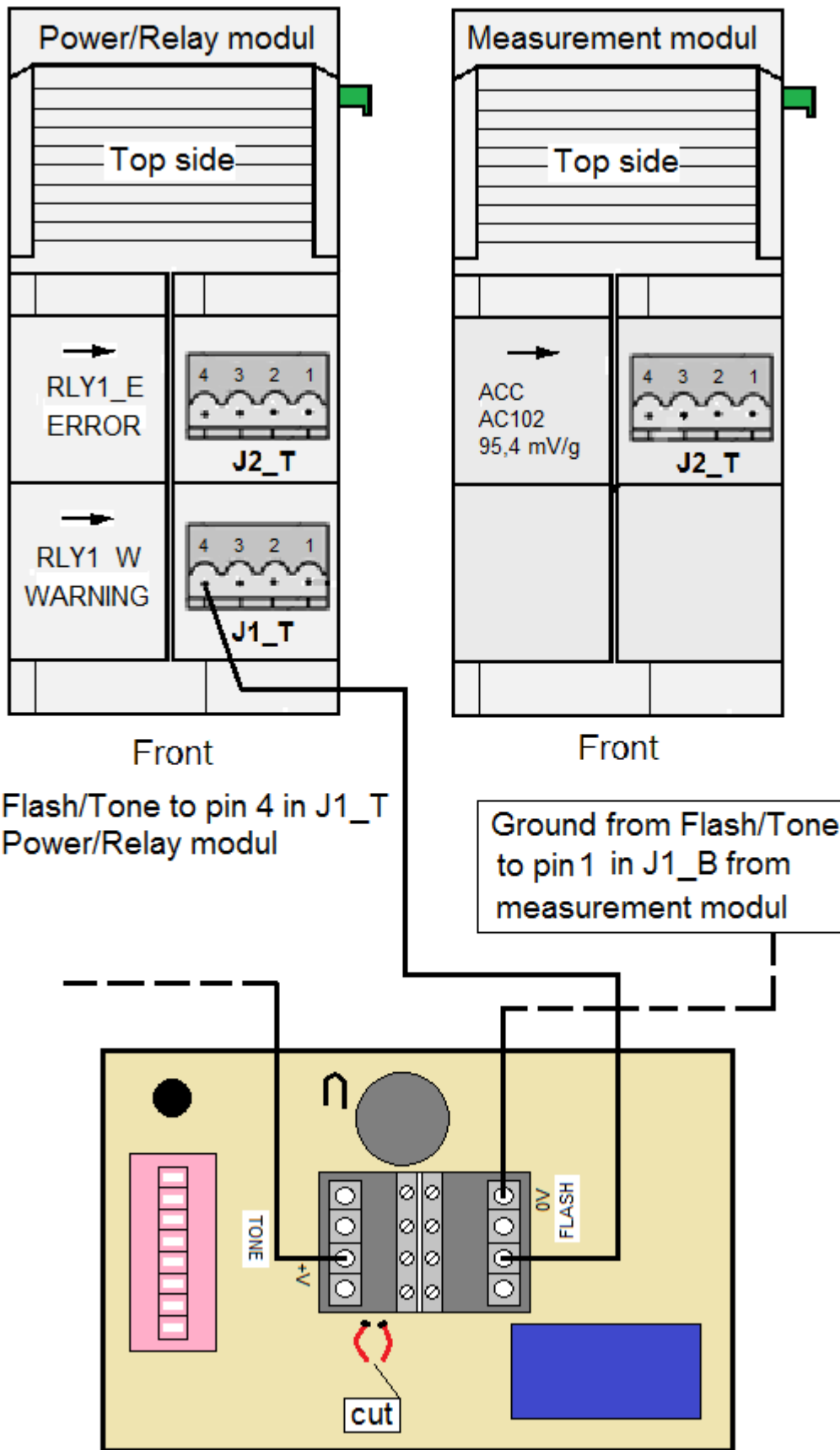

9.0 Application example

9.1 Application example for 2 measurement points, corresponds to a VIBER M2.

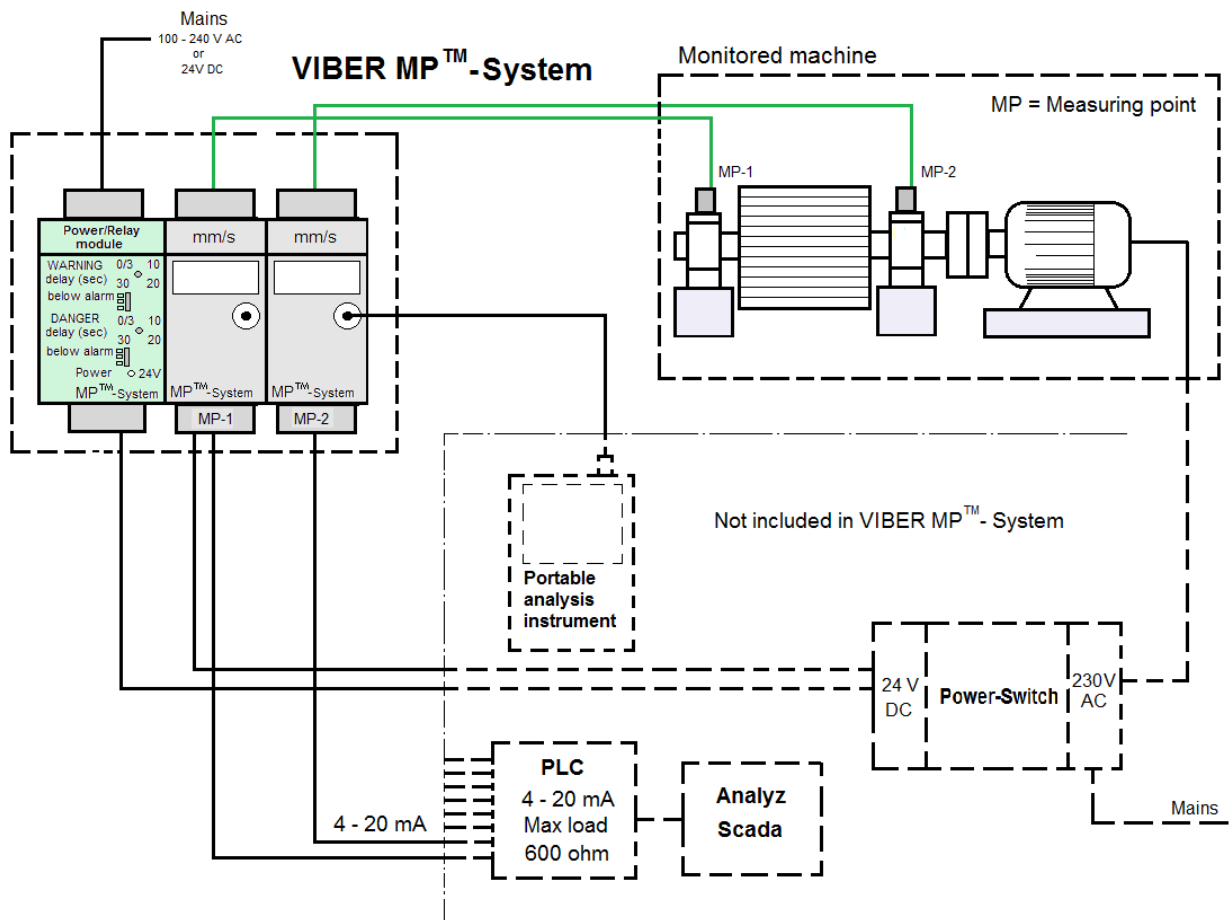



9.2 Application examples for 5 measuring points on a fan system

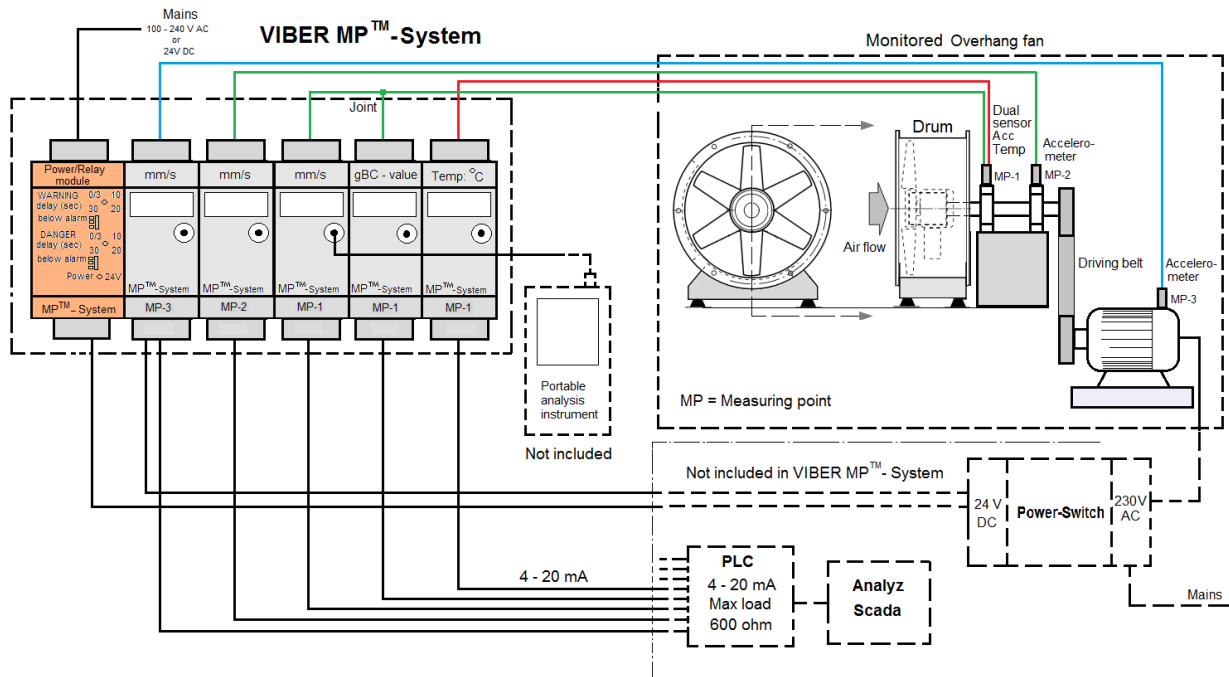

When only one accelerometer is used for simultaneous measurement of both acceleration and bearing condition, use two measurement modules, one for acceleration and one for bearing condition. **Note** that in this case must one of measuring modules power supply to the accelerometer be broken. This must be determined when ordering the system. Can not be changed afterwards

9.3 Application examples for 8 measuring points on a machine

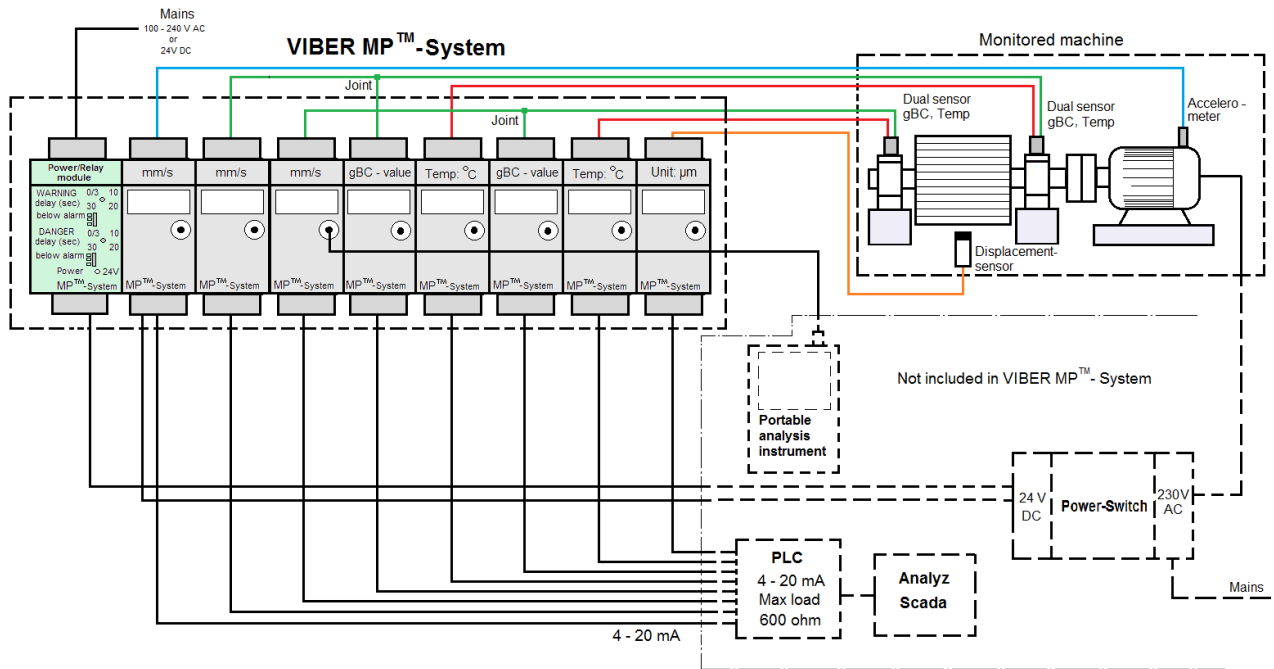

When only one accelerometer is used for simultaneous measurement of both acceleration and bearing condition, use two measurement modules, one for acceleration and one for bearing condition. **Note** that in this case must one of measuring modules power supply to the accelerometer be broken. This must be determined when ordering the system. Can not be changed afterwards.



Technical data VIBER MP-S (Machine Protector)			Comments
Vibration transducer	Accelerometer	Standard nom 100 mV/g	
	velocity sensor HG 91	5 mV/(mm/s)	(25 - 1600 Hz) 10 - 4000 Hz
	Proximity probe KIN-M18	4,0 V/(mm)	
Measuring range	Vibration Velocity in three range	0 - 10 mm/s RMS 0 - 20 mm/s RMS 0 - 100 mm/s RMS	Selectable in each channel (only performed by the supplier)
	Bearing Condition in three range	0 - 1,0 g RMS 0 - 2,0 g RMS 0 - 10,0 g RMS	Selectable in each channel (only performed by the supplier)
	Displacement	0 - 1000 µm (peak)	
Number of channels	1 - 12 CH		Up to 12 different measuring points on the same machine.
Frequency range	Vibration	2 - 1000 Hz 2 - 4000 Hz 2 - 10000 Hz 10 - 1000 Hz 10 - 4000 Hz 10 - 10000 Hz	Selectable in each channel (only performed by the supplier)
	Bearing condition	0,625 - 35 KHz - 3dB	
Vibration units	mm/s, g-value, µm		Selectable in each channel
Amplitud presentation	RMS		
Temperature sensor Range	Pt - 100 0 - 120 °C		(100 Ω at 0 °C)
	TA 102 3 - 120 °C		(10 mV/ °C)
Inaccuracy	Vibration	+/- 10%	For a particular transducer, +/- 3%
	Bearing Condition	+/- 10%	
	Temperature	+/- 10%	For a particular transducer, +/- 5%
Output current to PLC	4 - 20 mA		
Max load in PLC	600 ohm		
Alarm settings	Alarms are pre-set, for higher 71% and for lower 28% of full scale.		
Maximum break power for internal terminals	50 W (50V DC / 1,0 A)		(See page 6)
Power supply	100 - 240 V AC or 24 V AC/DC		
Enclosure protection	IP 65		Option
Operating temp. range	0 to 50 °C		
Weight			
Size	(L x W x H)		



VMI International AB
Gottorpsgatan 5
SE-582 73 Linköping, Sweden
Tel. +46 13 4743700
Fax. +46 13 133524
E-mail: info@vmiab.com
www.vmiab.com

Authorized distributor